



A121 – Pulsed Coherent Radar (PCR)

Datasheet v1.8



A121 Overview

The A121 is a radar system based on pulsed coherent radar (PCR) technology and is setting a new benchmark for power consumption and distance accuracy – fully integrated in a small package of 29 mm².

The A121 60 GHz radar system is optimized for high precision and ultra-low power, delivered as a one package solution with integrated Baseband, RF front-end, and antenna. This will enable easy integration into any portable battery driven device.

The A121 is based on leading-edge patented pulsed coherent radar technology with pico-second time resolution. The sensor can measure up to 23 meters and the actual measurable distance is dependent on object size, shape, and dielectric properties. For example:

- Water level measurement up to 23 meters with lens utilization.
- Human presence detection up to 7 meters with lens-free utilization.

The A121 60 GHz radar remains uncompromised by any natural source of interference, such as noise, dust, color and direct or indirect light.

Applications

- High precision distance measurements with mm accuracy and high update rate
- Proximity detection with high accuracy and the possibility to define multiple proximity zones
- Presence detection and velocity measurement
- Material detection and classification
- High precision object tracking, enabling robot navigation
- Gesture control
- Monitoring of vital life signs such as breathing and pulse rate

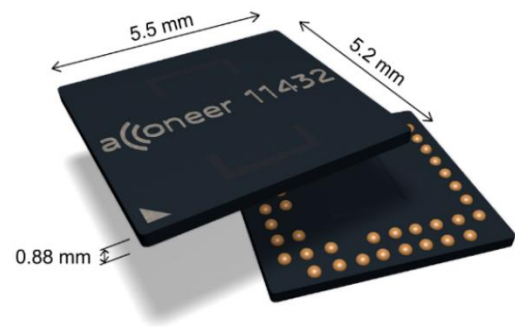

Features

- **Accurate distance ranging and movements**
 - Measures absolute range up to 23 m
 - Absolute accuracy in mm
 - Relative accuracy in μm
 - Possible to recognize movement and gestures for several objects
 - Support continuous and single sweep mode
 - HPBW typical of 65 (H-plane) and 53 degrees (E-plane)
- **Easy integration**
 - 60 GHz Pulsed Coherent Radar (PCR)
 - Integrated Baseband, RF front-end, and Antenna in Package
 - 5.5 x 5.2 x 0.88 mm fcCSP, 0.5 mm pitch
 - Can be integrated behind plastic or glass without any need for a physical aperture
 - Single reflowable component
 - 1.8 V single power supply, enable with Power on Reset (PoR)
 - 1.8 V or 3.3 V IO interface power supply
 - Clock input for crystal 24 MHz.
 - SPI interface for data transfer, up to 50 MHz SPI clock support
 - INTERRUPT support



Table of Contents

1	Revision History	4
2	Description	5
2.1	Functional Block Diagram	6
3	Pin Configuration and Functions.....	7
4	Specifications	10
4.1	Absolute Maximum Ratings.....	10
4.2	Environmental Sensitivity	10
4.3	Recommended Operating Conditions.....	11
4.4	Electrical Specification	11
4.5	Current Consumption	12
4.6	RF Specification.....	13
4.7	Distance Accuracy	13
4.8	Radial Resolution.....	14
4.9	Base RLG.....	15
4.10	A121 Temperature Sensor.....	15
5	Timing Requirements	16
5.1	Serial Peripheral Interface.....	16
6	Hardware integration	18
6.1	Bill of Materials (BOM).....	19
6.2	XTAL.....	19
6.3	Sensor startup.....	20
6.4	Layout Recommendations.....	20
6.5	VDIG power Supply	21
7	Software.....	22
8	Regulatory Approval	23
8.1	ETSI	23
8.1.1	EU type examination certificate.....	24
8.2	FCC Approval	25
8.2.1	FCC Grant Authorization.....	26
8.3	Industry Canada Approval	26
8.3.1	Regulatory Information Canada.....	27
8.3.2	Acceptance Certificate – Canada	28
8.4	MIC Approval	29
8.4.1	MIC Type Approval Certificates	30
9	Mechanical Data	32
9.1	Moisture Sensitivity Level and Recommended Reflow Profile.....	34
9.2	RoHS and REACH Statement	34
10	Abbreviations	35
	Disclaimer	36



1 Revision History

Revision	Comment
v0.1	Preliminary revision
v0.2	Table 4.6 updated
v0.3	Table 4.1, 4.3, 4.6, 7.1 updated
v0.4	Characterization data added: Ch 4.5, 4.7, 4.8, 4.10, 4.11 ETSI Regulatory approval added: Ch 8.1
v1.0	Released version
v1.1	Updated chapter 6.2 XTAL (corrected typo 0.3 to 0.58, corrected reference to crystal capacitors)
v1.2	FCC regulatory approval added: Ch 8.2
v1.3	Table 2 updated
v1.4	Table 10 updated
v1.5	Table 7 updated
v1.6	Table 4 updated Figure 3.1 updated
v1.7	MIC Type approval added; Ch 8.3. Table 8 updated. Industry Canada approval added Ch 8.3
v1.8	Page 2. Updated water level measurement range from 20 to 23 m.



2 Description

Note that explanations of definitions can be found at docs.acconeer.com/handbook.

The A121 is an optimized low-power, high-precision, 60 GHz radar sensor with integrated Baseband, RF front-end, and Antenna in Package (AiP).

The sensor is based on pulsed coherent radar (PCR) technology, featuring a leading-edge patented solution with picosecond time resolution. The A121 is the perfect choice for implementing high-accuracy, high-resolution sensing systems with low power consumption.

Ordering information

Part number	Package	Size (nom)	Primary component container
A121-001-T&R	fcCSP50	5.2 x 5.5 x 0.88 mm	Tape & reel
A121-001-TY	fcCSP50	5.2 x 5.5 x 0.88 mm	13" Tray

Acconeer A121 marking

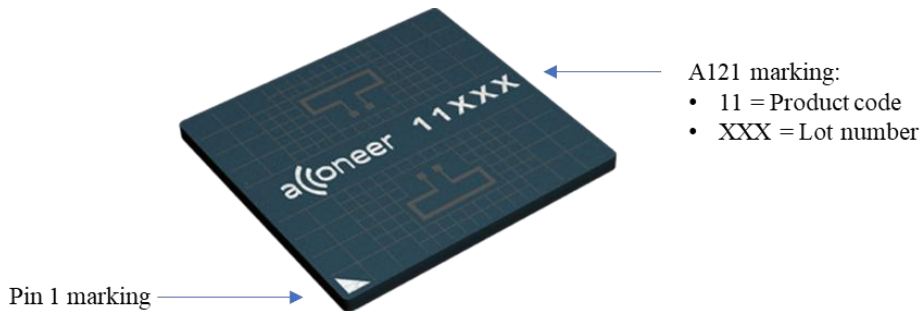



2.1 Functional Block Diagram

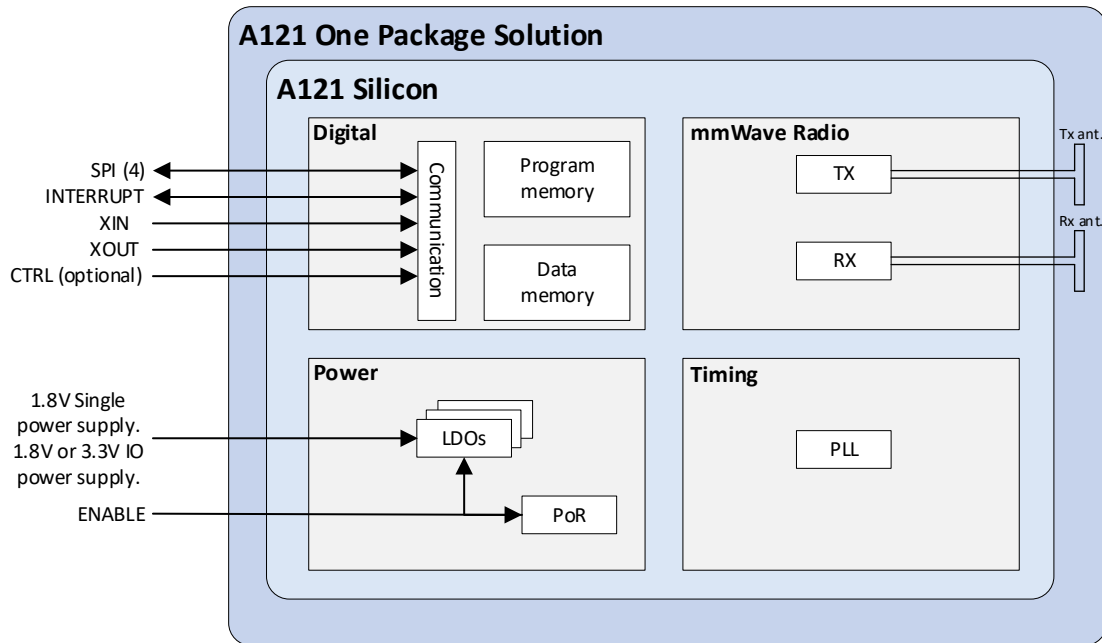

Figure 2.1 The A121 functional block diagram.

The A121 silicon is divided into four functional blocks: Power, Digital, Timing and mmWave radio.

The Power functional block includes LDOs and a Power on Reset (PoR) block. Each LDO creates its own voltage domain. The PoR block generates a Reset signal on each power-up cycle. To operate the A121, an external host CPU such as a microcontroller (MCU) is required.

The host application interfaces the Power functional block of the sensor via 1.8 V Single power supply, 1.8 V or 3.3 V IO power supply and ENABLE.

The Digital functional block includes sensor control and the data memory stores the radar sweep data. The external host CPU interfaces the A121 via an SPI interface, INTERRUPT signal and optional CTRL signal. The SPI, INTERRUPT, CTRL and ENABLE interfaces support 1.8 V or 3.3 V IO voltage levels.

The Timing block includes the timing circuitry. The PLL digital clock output is used to drive internal digital logic and is generated by a crystal oscillator that requires an external crystal (XIN/XOUT). Supported frequency of the external crystal is 24 MHz.

The mmWave radio functional block generates and receives radar pulses and includes transmitter (TX), receiver (RX) and interfaces toward the antennas in package. The A121 operates in the 57-64 GHz band.



3 Pin Configuration and Functions

The figure below shows the A121 pin configuration, bottom view and the antenna assignment, top view:

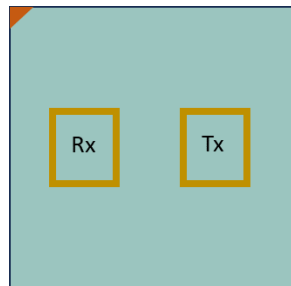
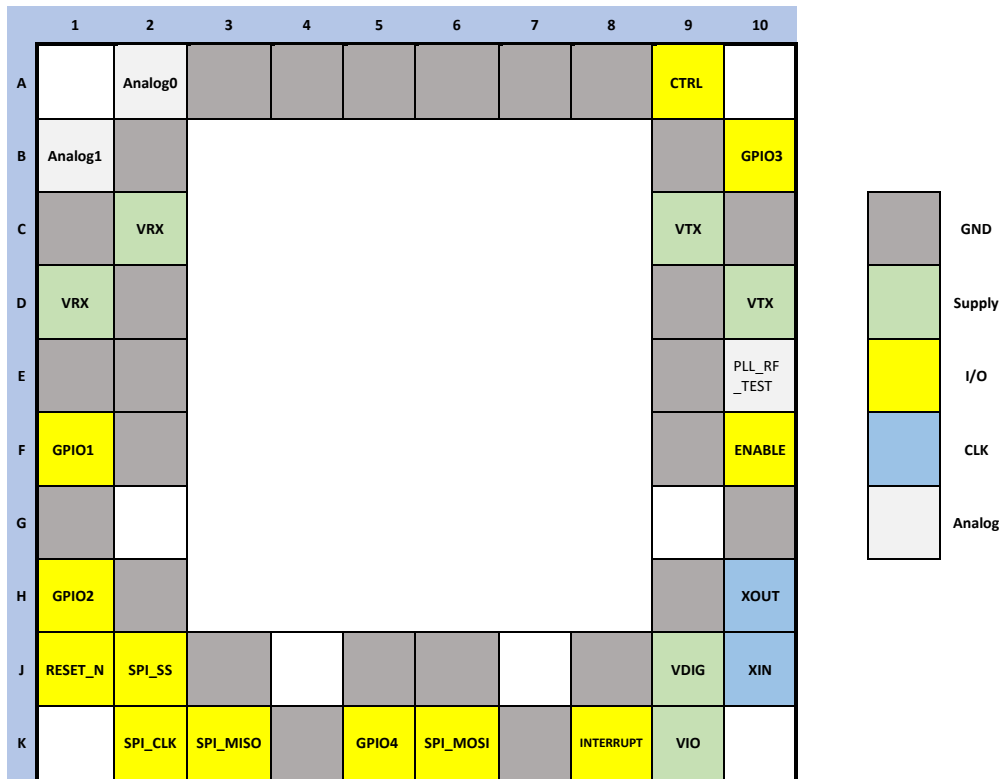

Figure 3.1. Pin configuration of the A121 sensor, bottom view and antenna assignment on top view.



Table 1 shows A121 pin functions.

Pin	Pin name	Pin type	Description	Comment
A3-A8, B2, B9, C1, C10, D2, D9, E1, E2, E9, F2, F9, G1, G10, H2, H9, J3, J5, J6, J8, K4, K7	GND	Ground	Must be connected to solid ground plane	
A2	Analog0	Analog	Not connected or ground. Ground recommended for optimized ground plane.	
A9	CTRL	I/O	For future use. Connect to ground	
B1	Analog1	Analog	Not connected or ground. Ground recommended for optimized ground plane.	
B10	GPIO3	I/O	For future use. Connect to ground	
C2, D1	VRX	Supply voltage	Supply voltage, RF part	
C9, D10	VTX	Supply voltage	Supply voltage, RF part	
E10	PLL_RF_TEST	Analog	Must be connected to solid ground plane	
F1	GPIO1	I/O	For future use. Connect to ground	
F10	ENABLE	I/O	To control OFF/ON/Hibernate/Reset Recommended to be connected to host MCU GPIO. ENABLE is active high	
H1	GPIO2	I/O	For future use. Connect to ground	
H10	XOUT	CLK	XTAL output	
J1	RESET_N	I/O	RESET_N must be connected to VIO	
J2	SPI_SS	I/O	SPI slave select, active low select.	
J9	VDIG	Supply voltage	Supply voltage, digital part	
J10	XIN	CLK	XTAL input	
K2	SPI_CLK	I/O	SPI Serial Clock	
K3	SPI_MISO	I/O	Master Input – Slave Output	
K5	GPIO4	I/O	For future use. Connect to ground	
K6	SPI_MOSI	I/O	Master Output – Slave Input	



Pin	Pin name	Pin type	Description	Comment
K8	INTERRUPT	I/O	Interrupt signal, used as an interrupt to the host. More details are found in section 7, <i>Description</i> .	Mandatory
K9	VIO	Supply voltage	Supply voltage, digital part	

Table 1. A121 sensor pin list.



4 Specifications

4.1 Absolute Maximum Ratings

The below table shows the A121 absolute maximum ratings over operating temperature range, on package, unless otherwise noted:

Parameter	Description	Min.	Max.	Unit
VRX ⁽¹⁾	1.8 V RF power supply	-0.3	2.0	V
VTX ⁽¹⁾	1.8 V RF power supply	-0.3	2.0	V
VDIG	1.8 V digital power supply	-0.3	2.0	V
VIO	I/O supply voltage	-0.5	3.63	V
T _{OP}	Operating temperature range	-40	125	°C
T _{STG}	High temperature storage		150	°C
T _J	High temperature junction		125	°C

Table 2. Absolute maximum ratings.

(1) VRX and VTX must never exceed VDIG.

Stresses beyond those listed in Table 2 may cause permanent damage to the device. These are stress ratings only and functional operation of the device at these conditions or at any other conditions beyond those indicated under Recommended Operating Conditions is not recommended. Exposure to absolute-maximum-rated conditions for extended periods of time may affect device reliability.

4.2 Environmental Sensitivity

The below table shows the A121 environmental sensitivity:

Parameter	Standard	Min	Max.	Unit
Reflow soldering temperature	J-STD-020		260	°C
Moisture Sensitivity Level	JESD22-A113	MSL3		
ESD, Charge Device Model (CDM)	JS-002, Class C3	1000		V
ESD, Human Body Model (HBM)	JS-001, Class 2	2000		V
Latch-up	JESD78, Class I	PASS		
JEDEC	JESD47	PASS		

Table 3. Environmental sensitivity.



4.3 Recommended Operating Conditions

The below table shows the A121 recommended operating conditions, on package:

Parameter	Min.	Typ.	Max.	Unit
Operating power supply voltage, VRX	1.71	1.8	1.89	V
Operating power supply voltage, VTX	1.71	1.8	1.89	V
Operating power supply voltage, VDIG	1.71	1.8	1.89	V
Operating power supply voltage, VIO (1.8V)	1.71	1.8	1.89	V
Operating power supply voltage, VIO (3.3V)	2.97	3.3	3.45	V
I/O operating range	-0.3		VIO+0.3	V
Operating temperature (T _{op})	-40		105	°C
Thermal resistance junction to free air ⁽¹⁾ (T _{JA})		44		°C/W

Table 4. Recommended operating conditions.

(1) Based on 27x27 mm, 2 layer PCB

4.4 Electrical Specification

The below table shows the A121 electrical DC specification conditions, on package, T_{op} = -40°C to 105°C:

Parameter	Min.	Typ.	Max.	Unit
Current into any power supply	0		100	mA
I/O V _{IL} Low-level input voltage	-0.3		0.10*VIO	V
I/O V _{IH} High-level input voltage	0.90*VIO		VIO+0.3	V
I/O V _{OL} Low-level output voltage	0		0.4	V
I/O V _{OH} High-level output voltage	1.6		VIO	V
I/O I _{OL} (VOL = 0.4 V)	4.56	7.8	12.4	mA
I/O I _{OH} (VOH = VIO-0.4)	3.42	5.8	9.16	mA
I/O I _{IL} Low-level input current			<1	µA
I/O I _{IH} High-level input current			<1	µA

Table 5. Electrical DC conditions.

The below table shows the A121 electrical AC specification conditions, on package, at T_{op} = -40°C to 105°C:

Parameter	Min.	Typ.	Max.	Unit
I/O output operating frequency ⁽¹⁾	0		100	MHz
I/O minimum positive and negative pulse	6.25			ns

Table 6. Electrical AC conditions.

(1) Load capacitance 2 pF



4.5 Current Consumption

Table 7 summarizes the steady-state current consumption for the sensor states at all power terminals (VDIG, VIO, VRX, VTX), VIO 1.8 V, at $T_{op} = 25^{\circ}\text{C}$. A power state defines in what mode the sensor waits in between measurements and where DEEP_SLEEP, SLEEP and READY states are configurable.

Parameter		Typ.	Unit
OFF	VDIG	0.34	μA
OFF	VIO	0	μA
OFF	VRX	0	μA
OFF	VTX	0.06	μA
HIBERNATE	VDIG	11.0	μA
HIBERNATE	VIO	0.05	μA
HIBERNATE	VRX	0.03	μA
HIBERNATE	VTX	0.02	μA
DEEP_SLEEP	VDIG	922	μA
DEEP_SLEEP	VIO	43.4	μA
DEEP_SLEEP	VRX	34.1	μA
DEEP_SLEEP	VTX	39.3	μA
SLEEP	VDIG	1.35	mA
SLEEP	VIO	43.4	μA
SLEEP	VRX	55.7	μA
SLEEP	VTX	59.9	μA
READY	VDIG	58.1	mA
READY	VIO	43.8	μA
READY	VRX	3.57	mA
READY	VTX	1.91	mA
MEASURE, PROFILE 1	VDIG	64.1	mA
MEASURE, PROFILE 1	VIO	-0.01	μA
MEASURE, PROFILE 1	VRX	5.31	mA
MEASURE, PROFILE 1	VTX	5.12	mA
MEASURE, PROFILE 2	VDIG	64.4	mA
MEASURE, PROFILE 2	VIO	-0.01	μA
MEASURE, PROFILE 2	VRX	5.49	mA
MEASURE, PROFILE 2	VTX	3.77	mA
MEASURE, PROFILE 3	VDIG	64.6	mA
MEASURE, PROFILE 3	VIO	0.04	μA
MEASURE, PROFILE 3	VRX	5.93	mA
MEASURE, PROFILE 3	VTX	4.86	mA
MEASURE, PROFILE 4	VDIG	64.6	mA



MEASURE, PROFILE 4	VIO	0.03	μA
MEASURE, PROFILE 4	VRX	6.32	mA
MEASURE, PROFILE 4	VTX	5.38	mA
MEASURE, PROFILE 5	VDIG	64.6	mA
MEASURE, PROFILE 5	VIO	-0.02	μA
MEASURE, PROFILE 5	VRX	7.09	mA
MEASURE, PROFILE 5	VTX	6.40	mA

Table 7. Steady-state current ratings at power terminals for the sensor states.

4.6 RF Specification

The below table shows the A121 RF specification at $T_{op} = 25^{\circ}\text{C}$:

Parameter	Min.	Typ.	Max.	Unit
Operating frequency range	57		64	GHz
EIRP		11.4		dBm
TX HPBW, E-plane ⁽¹⁾	42	53	64	degrees
TX HPBW, H-plane ⁽¹⁾	52	65	78	degrees

Table 8. A121 RF specification.

(1) Based on simulation

4.7 Distance Accuracy

Table 9 summarizes the distance accuracy in terms of typical standard deviation over units for all profiles at $T_{op} = 25^{\circ}\text{C}$. Results based on distance detector output.

Profile	Typ. std	Unit
1	2.67	mm
2	3.45	mm
3	2.83	mm
4	3.38	mm
5	5.05	mm

Table 9. Distance accuracy.



4.8 Radial Resolution

Table 10 summarizes the radial resolution given as FWHM power in terms of typical mean value and standard deviation over units for all profiles at $T_{op} = -40^{\circ}\text{C}$ to 105°C . Radial resolution gives the minimum measurable radial distance between two objects.

Profile	T (°C)	Typ.		Unit
		mean	Std.	
1	-40	33	1.0	mm
1	25	30	1.0	mm
1	105	26	0.7	mm
2	-40	56	1.3	mm
2	25	55	1.4	mm
2	105	54	1.4	mm
3	-40	95	2.6	mm
3	25	89	2.7	mm
3	105	85	2.0	mm
4	-40	134	4.2	mm
4	25	129	4.7	mm
4	105	122	3.4	mm
5	-40	230	18.0	mm
5	25	222	20.3	mm
5	105	204	16.7	mm

Table 10. Radial resolution



4.9 Base RLG

Table 11 summarizes the typical radar loop gains for different sensor profile configurations, HWAAS=1, typical ratings at $T_{op} = -40^{\circ}\text{C}$ to 105°C . SNR and RLG scales linearly with HWAAS, meaning a 3dB increase for every doubling of HWAAS.

Profile	T (°C)	Typ.		Unit
		mean	Std.	
1	-40	15	0.7	dB
1	25	11	0.8	dB
1	105	4	1.1	dB
2	-40	17	0.7	dB
2	25	13	0.7	dB
2	105	9	0.6	dB
3	-40	22	0.6	dB
3	25	19	0.7	dB
3	105	15	0.6	dB
4	-40	24	0.7	dB
4	25	20	0.7	dB
4	105	17	0.6	dB
5	-40	25	0.9	dB
5	25	22	0.9	dB
5	105	18	0.8	dB

Table 11. Typical RLG values for the sensor profile configurations.

4.10 A121 Temperature Sensor

The A121 includes an internal temperature sensor that can be used for relative temperature measurements. Such measurements can, for example, be used to predict change of the signal and noise components. The typical relative deviation from true temperature change is 4.4%. I.e., given a change in temperature x , the measured temperature typically changes $x \pm x \cdot 4.4\%$.



5 Timing Requirements

5.1 Serial Peripheral Interface

The Serial Peripheral Interface (SPI) is a 4-wire serial bus, used for configuration and reading output from the A121 radar sensor. The A121 radar sensor is an SPI slave device connected to the SPI master, as described in Figure 5.1. The A121 allows several devices to be connected on the same SPI bus, with a dedicated slave-select signal. Daisy-chain is not supported.

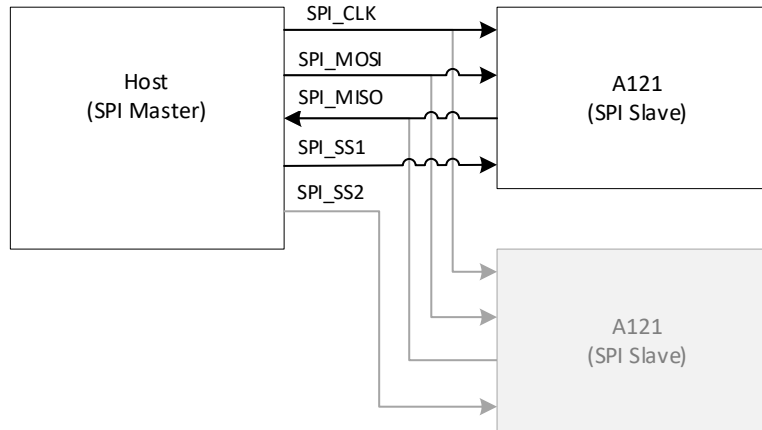

Figure 5.1. SPI master-slave connection.

The serial data transfer input (MOSI) and output (MISO) to the A121 are synchronized by the SPI_CLK. The Slave Select signal (SS) must be low before and during transactions. The MOSI is always read on the rising edge of SCLK and the MISO changes value on the falling edge of SPI_CLK (SPI mode 0, CPOL/CPHA = 0). SS requires release in between transactions. See Figure 5.2 and Table 12 for timing characteristics.

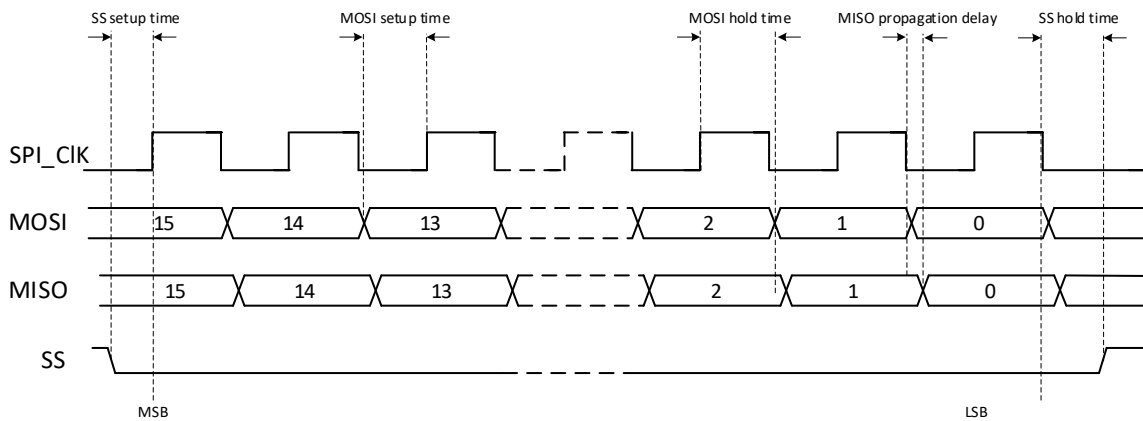

Figure 5.2. Timing diagram of SPI, CPOL=0 and CPHA=0.



Parameter	Min.	Typ.	Max.	Unit
Clock frequency			50	MHz
SS setup time	1.0			ns
SS hold time	2.0			ns
MOSI setup time	1.0			ns
MOSI hold time	2.5			ns
MISO Propagation delay VIO=3.3V and 10 pF Load	2.0		5.5	ns
MISO Propagation delay (VIO=1.8, Radar System Software Setting, 10pF)	3.0		7.5	ns

Table 12. SPI timing characteristics.



6 Hardware integration

The A121 sensor can be configured for a 3.3 V or 1.8 V host interface as shown in Figure 6.1 and Figure 6.2.

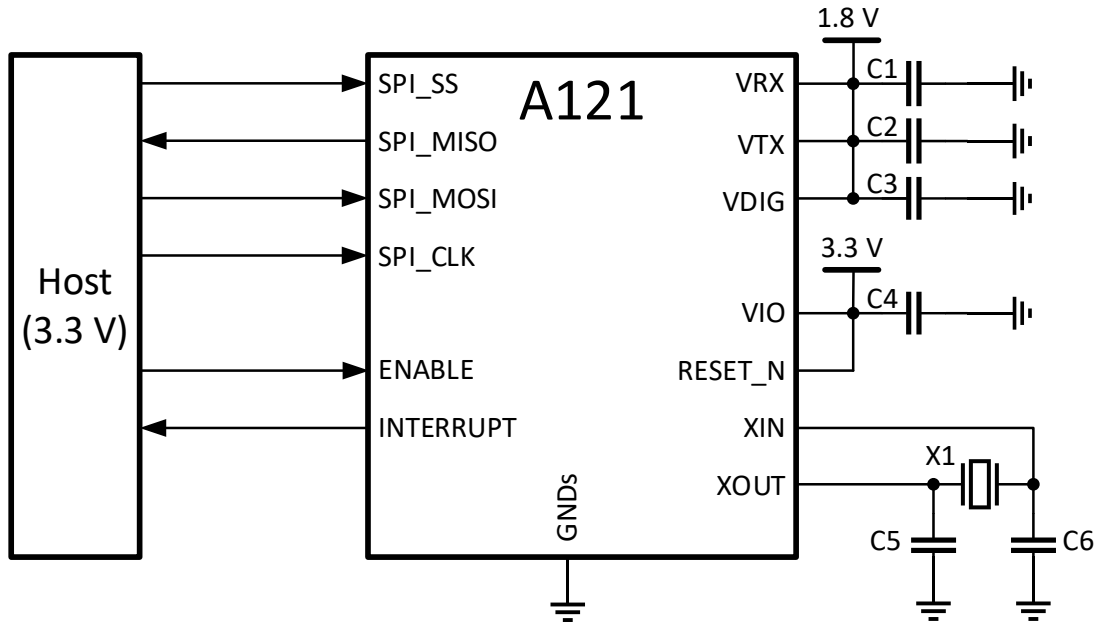

Figure 6.1. Recommended integration of the A121 radar sensor for 3.3 V host interface.

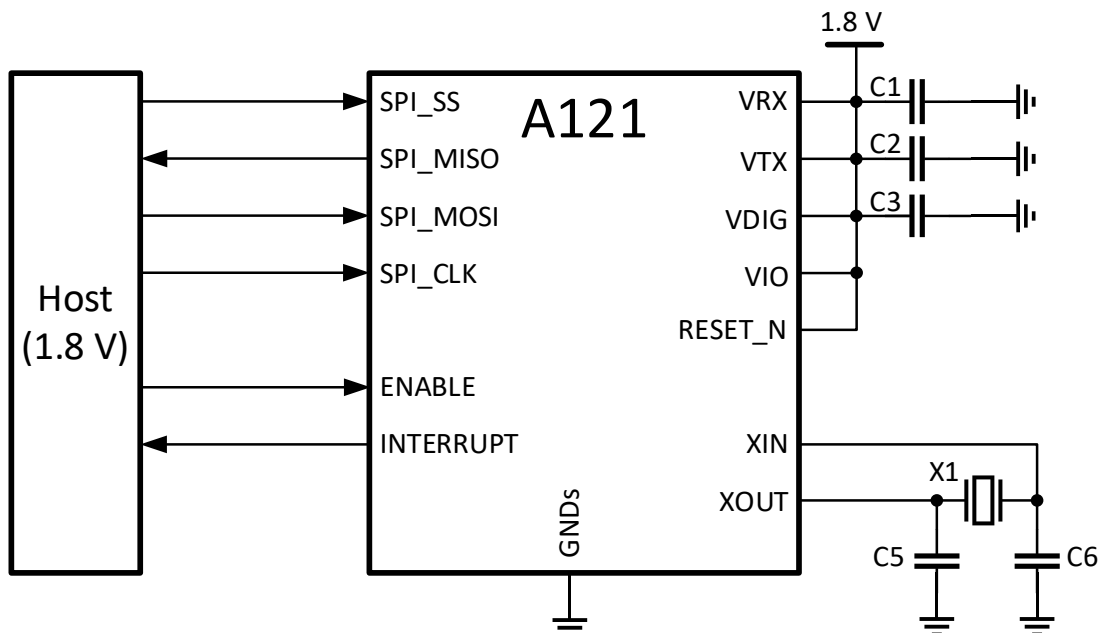

Figure 6.2 Recommended integration of the A121 radar sensor for 1.8 V host interface.

6.1 Bill of Materials (BOM)

Table 13 shows BOM for integration of the A121 using a crystal as input clock source:

Component	Value	Description
C1, C2, C3, C4	1 μ F	Decoupling for VRX, VTX, VDIG and VIO.
X1	24 MHz	Crystal resonator
C5, C6	See Ch. 6.2	XTAL frequency tuning capacitors

Table 13. BOM list.

6.2 XTAL

The A121 sensor has a built-in crystal oscillator that requires an external crystal component (XTAL) that is shown in Figure 6.3.

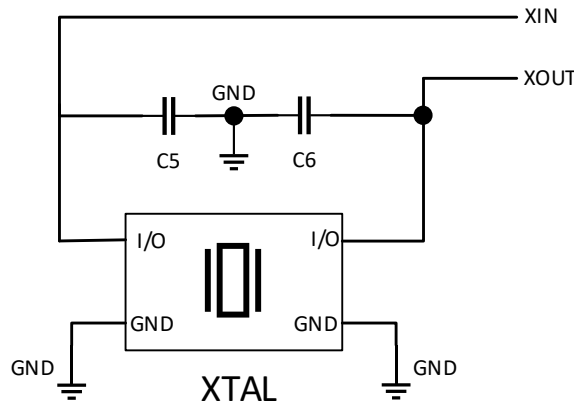

Figure 6.3. External XTAL schematics.

To enable the internal XTAL oscillator to drive the external resonator, Equation 1 must be fulfilled.

$$f * C_{pin}^{0.8} * R_{ESR}^{0.61} < 0.7 \quad (\text{Equation 1})$$

$$C = 2(C_L - C_{stray}) \quad (\text{Equation 2})$$

$$C_{pin} = C + C_{stray} * 2 \quad (\text{Equation 3})$$

The capacitance values are calculated in Equation 2. C_L and R_{ESR} are XTAL parameters and vary from XTAL to XTAL. The stray capacitance is the sum of the capacitance between XIN and XOUT, that is, the PCB trace capacitance plus package capacitance; 2 to 5 pF is a general estimation.

Example:

- $f = 24$ MHz
- $C_L = 9$ pF
- $R_{ESR} = 40$ ohm

Assuming $C_{stray} = 5$ pF gives $C5, C6 = 8$ pF and that the condition is met with the result $0.58 < 0.7$.



6.3 Sensor startup

The power-up and power-down sequences are shown in Figure 6.4.

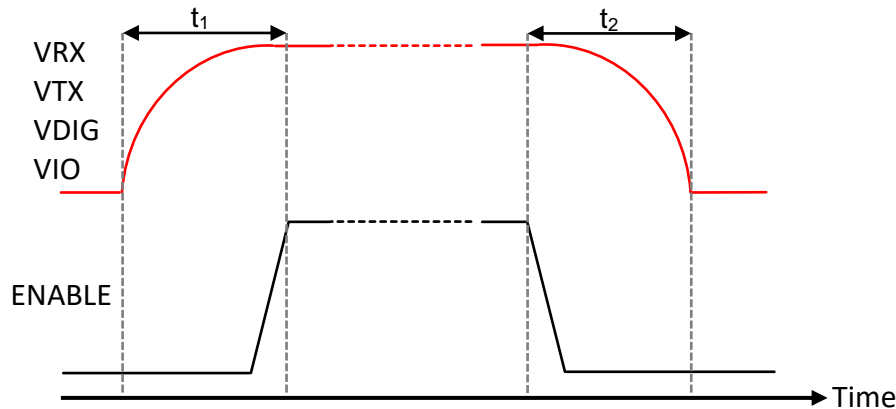

Figure 6.4. Power-up and power-down sequences.

The power supplies VRX, VTX, VDIG and VIO can be turned on and off in any order. ENABLE should be turned on after or simultaneously with VDIG and VIO, whichever is turned on last. The A121 should however not be considered as in state “ON” until all supply voltage levels are stable and ENABLE is high. The time constant t_1 in Figure 6.4 denotes this time. The actual value of t_1 depends on the power supply and the decoupling capacitors used. Any I/O must be held at 0 V during time t_1 .

After power-up is complete, the sensor is ready for SPI communication and can be loaded with a program. Note that time between ENABLE high until start of SPI communication is dependent on XTAL startup time, typically 2 ms.

Up until the point where the sensor’s program is started, the INTERRUPT is in a high impedance state. After the sensor’s program has started, the INTERRUPT is configured as a push-pull CMOS output.

The power down sequence is initiated by setting ENABLE low. After that, all supplies can be turned off. Any I/O inputs on A121 must be set to 0 V before or simultaneously with VIO going low to avoid forward-biasing the internal ESD protection diodes.

6.4 Layout Recommendations

The sensor antennas are of a folded dipole type, with its main ground reference being the internal package ground plane, extending below the whole area of the sensor. To further enhance the directivity of the sensor, the package ground plane should be extended by soldering all GND pads to the PCB top layer ground. In terms of regulatory compliance, any openings in the ground plane inside the A121 footprint must be significantly smaller than the wavelength (5 mm in free space) to effectively shield off any disturbance.

It is important to consider PCB layout for optimal RLG performance. PCB layout guidelines can be found in the document “Hardware and physical integration guideline”.



6.5 VDIG power Supply

The A121 power domain “VDIG” is sensitive to power supply ripple which may result in performance degradation. Table 14 provides the power supply ripple specification for VDIG.

Frequency (Hz)	Min.	Typ.	Max.	Unit
10 000			25	mV _{pp}
100 000			25	mV _{pp}
1 000 000			25	mV _{pp}
4 000 000			25	mV _{pp}

Table 14. Power supply ripple specification for VDIG.

If the VDIG voltage source violates the power supply ripple specification, an LC filter as displayed in Figure 6.5 can be used. This filter has a cut-off frequency of 30 kHz. The exact values for the LC filter depend on the frequency and amplitude of the ripple. Be aware of the LC filter peaking at the series resonance frequency $f=1/(2\pi\sqrt{LC})$. A small snubber resistor, 250 mΩ in the example filter, can be inserted to lower the Q factor.

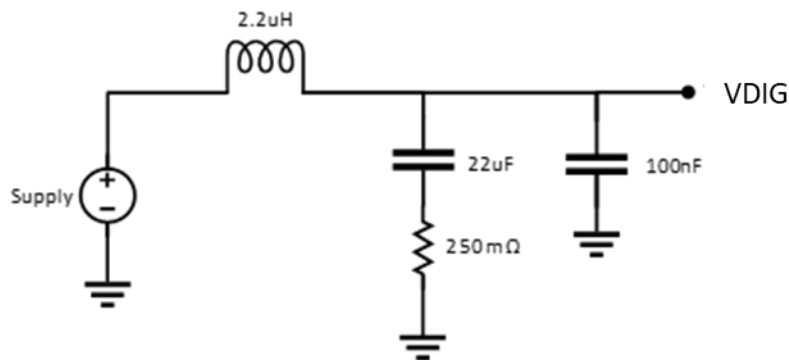

Figure 6.5. LC supply filter.



7 Software

The Acconeer software is written in C and is portable to any OS and HW platform. The Acconeer software is executed on Host MCU.

The below figure shows the A121 software offer.

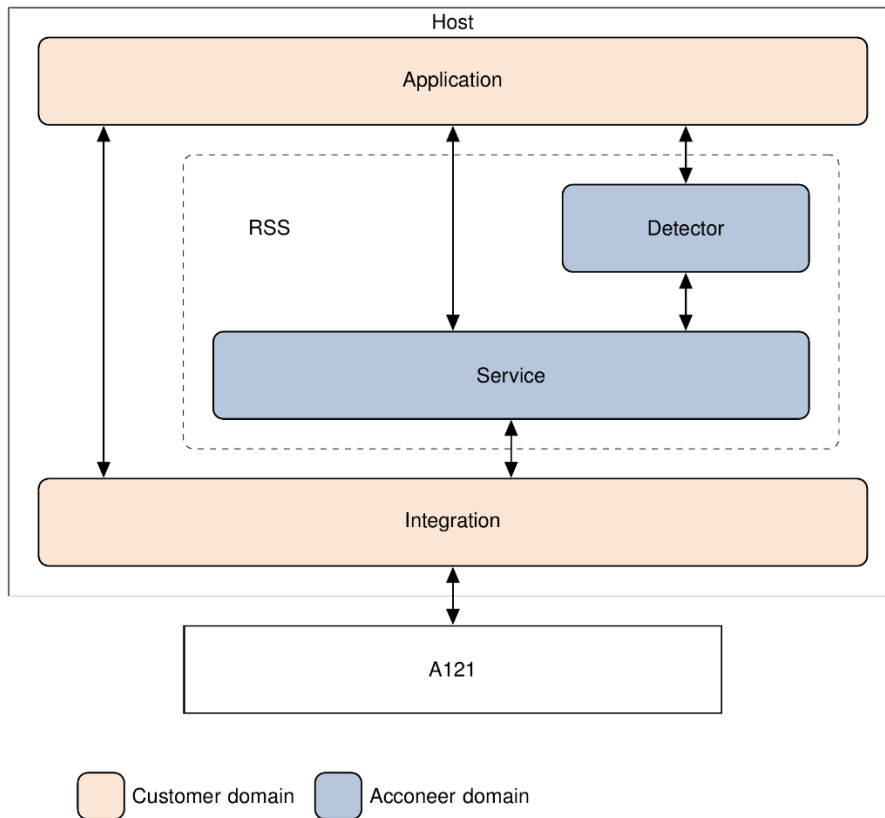

Figure 7.1. Acconeer Software offer.

RSS (Radar System Software) provides an API for controlling and retrieving data from the sensor. The data output can be on two different levels, Service and Detector.

Service output is radar data with some pre-processing.

Detector output is based on Service output but uses further processing to create a result such as a distance or presence detection.

Customer can either use Acconeer detector or develop their own signal processing based on Service data.

Acconeer provides several example applications to support customer own application development. Also, guidelines are provided for application development utilizing the Acconeer RSS API.

Integration software shall implement functions defined in a definitions file provided in Acconeer Software offer. This includes handling of SPI, ENABLE, INTERRUPT and CTRL, as well as potential OS functions.

See reference A121 User Guide HAL Software Integration for guideline on software integration and HAL implementation (<https://www.acconeer.com/products>).

Acconeer provides reference integrations as source code.



8 Regulatory Approval

To bring a product, emitting radio waves to the market, it is required to certify or declare conformity for the device to assure that necessary regulatory conditions are met, and necessary approvals have been obtained for the customer's specific product and use case. Please contact the certification body for detailed conditions of conformity.

8.1 ETSI

Hereby, Acconeer declares that the A121 sensor is compliant with the European commission radio equipment directive 2014/53/EU article 3.1 and 3.2.



8.1.1 EU type examination certificate

EU Type Examination Certificate



CTC advanced
member of RWTÜV group

Certificate Holder: Acconeer AB
 Västra Varvsgatan 19
 211 77 Malmö
 Sweden

Product Manufacturer: See Certificate Holder

Product Designation: A121

Product Description: Short Range Device Module



Bundesnetzagentur

BNetzA-b5-02/51-52

authorized by the German Government to act as Notified Body in accordance with the RE Directive 2014/53/EU of 16 April 2014.

Conformity Assessment:

Essential requirements	Examined documentation	Result
Radio spectrum RED, Article 3.2	Technical documentation including test report	conform

EU Type Examination Certificate:
 In accordance with Annex III of the European Council Directive 2014/53/EU on radio equipment, our opinion is that this equipment type complies with the essential requirements stated above.

Marking:
 The product shall be marked with the CE marking as required in the Council Directive 2014/53/EU.

Annexes:
 The certificate is only valid in conjunction with the following number of annexes: 1

Validity:
 Conformity is provided unless changes/modifications have been done to the standard and/or assessed type of equipment.

Certificate Registration No.: **CE 0682**

T819043P-01-TEC

CTC advanced GmbH

ce=Frank.Muchitsch,
 o=CTC advanced GmbH,
 ou=pc-8724-2021-11-26,
 email=Frank.Muchitsch@
 ctcdvanced.com, c=DE
 2022.11.26 14:57:00
 +01'00'

Authorized signature / title



GERMAN NOTIFIED BODY
 EUROPEAN ID-NO. 0682

CTC advanced GmbH
 Unterturheimer Str. 6-10 | 66117 Saarbrücken | Germany | www.ctcdvanced.com



8.2 FCC Approval

Hereby, Acconeer declares that the A121 sensor has limited single-modular transmitter approval granted by FCC. Acconeer has not approved any changes to this device. Any changes or modifications to this device could invalidate the FCC approval.

The A121 sensor meets the title 47 of the Code of Federal Regulations, part 15 section 15.255 (c)(3) for pulsed field disturbance sensors/radars operating in the 57–64 GHz band. The transmit duty cycle is evaluated during any 0.3 μ s time window by summing the total time that pulses are emitted during this time window. The A121 sensor is not permitted for use on satellites or aircrafts, where there is little attenuation of RF signals by the body/fuselage of the aircraft. The host product manufacturer is responsible for compliance with any other FCC rules that apply to the host not covered by the modular transmitter grant of certification, including Part 15 Subpart B and Suppliers declaration of conformity, unless final device is expressly exempted by the rules.

The host manufacturer should refer to guidance in KDB 996369 and ensure that the module limiting conditions are fulfilled for the host product and that the installation instructions provided by Acconeer in this document have been followed. Host product manufacturers are responsible to perform a limited set of transmitter module verification testing, including radiated spurious emissions test, to ensure that the product is in compliance with the FCC rules.

The product has integrated antennas in package, it is not possible to connect trace antenna.

MPE RF exposure testing is not needed as the available maximum time-averaged power of the module is no more than 1 mW, according to 47 CFR 1.1307(b)(3)(i)(A). Co-location of this module with other transmitters that operate simultaneously are required to be evaluated using the FCC multi-transmitter procedures.

The modular approval covers use with dielectric lens that converge or diverge the electromagnetic waves at least in one plane of radiation (E or H plane). Only lenses that result in the same or lower EIRP are covered by the limited single-modular transmitter approval.

The host device shall be labelled to identify the modules within the host device, which means that the host device shall be labelled to display the FCC ID of the module preceded by words "Contains transmitter module" or "Contains", E.g.

Contains FCC ID: 2AQ6KA1201

The module integrator must include below statement:

This device complies with Part 15 of the FCC rules. Operation is subject to the following two conditions: (1) this device may not cause interference, and (2) this device must accept any interference, including interference that may cause undesired operation of the device.



8.2.1 FCC Grant Authorization

TCB

**GRANT OF EQUIPMENT
 AUTHORIZATION**

TCB

**Certification
 Issued Under the Authority of the
 Federal Communications Commission
 By:**

**CTC advanced GmbH
 Untertuerkheimer Strasse 6-10
 66117 Saarbruecken,
 Germany**

**Date of Grant: 09/05/2023
 Application Dated: 08/21/2023**

**Acconeer AB
 mikael.rosenhed@acconeer.com
 mikael.egard@acconeer.com
 Malmo, 21177
 Sweden**

Attention: Mikael Rosenhed , Product Manager

NOT TRANSFERABLE

EQUIPMENT AUTHORIZATION is hereby issued to the named GRANTEE, and is VALID ONLY for the equipment identified hereon for use under the Commission's Rules and Regulations listed below.

FCC IDENTIFIER: 2AQ6KA1201
Name of Grantee: Acconeer AB
Equipment Class: Part 15 Field Disturbance Sensor
Notes: Pulsed coherent radar module
Modular Type: Limited Single Modular

<u>Grant Notes</u>	<u>FCC Rule Parts</u>	<u>Frequency Range (MHZ)</u>	<u>Output Watts</u>	<u>Frequency Tolerance</u>	<u>Emission Designator</u>
	15.255	57000.0 - 64000.0	0.012		

Output power listed is average EIRP.

This limited modular approval is valid for the configuration as tested. The radar module A121 was tested when mounted on the reference board XS121. All measurements were performed with and without lenses LH113.

Measured average EIRP of EUT within 0.3µs with lenses LH113: 11.6 dBm

Measured average EIRP of EUT within 0.3µs without lenses: -3.7 dBm

RF exposure compliance is addressed for 1.1310 and 2.1093 limits. The module must not transmit simultaneously with any other antenna or transmitter, except in accordance with FCC's multi-transmitter product procedure. Any variation from tested design requires new evaluation and may result in Permissive change procedure or new certification.

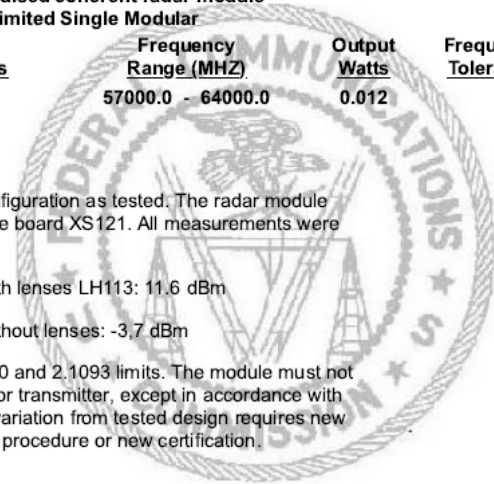

8.3 Industry Canada Approval

The A121 sensor module meets the radio requirements for the 57-64 GHz band.

IC certification number: 24388-A121.

Le module du capteur A121 répond aux conditions de la bande 57-64 GHz.

Numéro d'identification IC: 24388-A121



8.3.1 Regulatory Information Canada

Acconeer has not approved any changes to this device. Any changes or modifications to this device could invalidate the usage of the module.

Acconeer n'a pas approuvé aucun changement de ce dispositif. Tout changement ou toute modification de ce dispositif pourrait invalider l'usage du module.

This device complies with Industry Canada's licence-exempt RSSs. Operation is subject to the following two conditions: (1) This device may not cause interference; and (2) This device must accept any interference, including interference that may cause undesired operation of the device.

Le présent appareil est conforme aux CNR d'Industrie Canada applicables aux appareils radio exempts de licence. L'exploitation est autorisée aux deux conditions suivantes : (1) l'appareil ne doit pas produire de brouillage, et (2) l'utilisateur de l'appareil doit accepter tout brouillage radioélectrique subi, même si le brouillage est susceptible d'en compromettre le fonctionnement.

RF Exposure

Radiation Exposure Statement This equipment complies with Canada radiation exposure limits set forth for an uncontrolled environment. This equipment should be installed and operated with minimum distance 20cm between the radiator & your body.

Déclaration d'exposition aux radiations

Cet équipement est conforme Canada limites d'exposition aux radiations dans un environnement non contrôlé. Cet équipement doit être installé et utilisé à distance minimum de 20cm entre le radiateur et votre corps.

Labelling requirements for the host device

The host device should be labelled to identify the modules within the host device, which means that the host device shall be labelled to display the IC of the module preceded by words "Contains transmitter module" or "Contains", or similar wording expressing the same meaning, as follows

Contains IC: 24388-A121

Le dispositif hôte doit être étiqueté afin d'identifier les modules du dispositif hôte, ce qui veut dire que le dispositif hôte doit être étiqueté pour exposer le IC du module précédé par les mots "Contient module émetteur" ou "Contient", ou des termes similaires exprimant le même sens, comme suit:

Contient IC: 24388-A121



8.3.2 Acceptance Certificate – Canada



cetecom advanced GmbH
CAB Identifier DE0001

based on the Comprehensive Economic
and Trade Agreement (CETA) between
the European Community and Canada



TECHNICAL ACCEPTANCE CERTIFICATE - CANADA

Certificate Holder	Acconeer AB Västra Varvsgatan 19 21177, Malmö Sweden
ISED Certification Number	24388-A121
Product Description	Short range radar
cetecom advanced Registration No.	1-5794/23-2-4
OATS Facility	cetecom advanced GmbH Untertuerkheimer Str. 6-10 66117 Saarbruecken Germany Phone:49 681 598 0 Website: www.cetecomadvanced.com
OATS Facility ID	3462C

Certification of equipment means only that the equipment has met the requirements of the above-noted specification. License applications, where applicable to use certified equipment, are acted on accordingly by the ISED issuing office and will depend on the existing radio environment, service and location of operation. This certificate is issued on condition that the holder complies and will continue to comply with the requirements and procedures issued by ISED. The equipment for which this certificate is issued shall not be manufactured, imported, distributed, leased, offered for sale or sold unless the equipment complies with the applicable technical specifications and procedures issued by ISED.

La certification du matériel signifie seulement que le matériel a satisfait aux exigences de la norme indiquée ci-dessus. Les demandes de licences nécessaires pour l'utilisation du matériel certifié sont traitées en conséquence par le bureau de délivrance d'ISDE et dépendent des conditions radio ambiantes, du service et de l'emplacement d'exploitation. Le présent certificat est délivré à la condition que le titulaire satisfasse et continue de satisfaire aux exigences et aux procédures d'ISDE. Le matériel à l'égard duquel le présent certificat est délivré ne doit pas être fabriqué, importé, distribué, loué, mis en vente ou vendu à moins d'être conforme aux procédures et aux spécifications techniques applicables publiées par ISDE.

*I hereby attest that the subject equipment was tested and found in compliance with the above-noted specification.
J'atteste par la présente que le matériel a fait l'objet d'essai et jugé conforme à la spécification ci-dessus.*

Place, date of issue

Saarbruecken, 2024-09-18

cetecom advanced GmbH

Michael Dorongovski / FCB

cetecom advanced GmbH
Untertuerkheimer Str. 6-10 | 66117 Saarbruecken | Germany | www.cetecomadvanced.com



8.4 MIC Approval

Hereby, Acconeer declares that the A121 sensor is granted by MIC:

- Certification ordinance article 2-1-8, Spec. Low power, motion sensor 57-66 GHz.
Certificate number: 005-103274
- Certification ordinance article 2-1-8, Spec. Low power, motion sensor 57-64 GHz.
Certificate number: 005-103273



8.4.1 MIC Type Approval Certificates

TÜVRheinland[®]

(Translation)

Type Approval Certificate

Classification	Certification Ordinance Article 2-1-8 Spec. Low Power, Motion Sensor 57-66GHz
Type of emission, frequency and antenna power	K3N 61.5GHz 0.007W
Model Name	A121 + lens
License Holder	Acconeer AB
Manufacturer	Acconeer AB
Certificate number	005-103274
Certification date	2024-06-20

Approval as mentioned above is granted under the provisions of Article 38-24-1 of the Radio Law.

JRF-005-103274-001

2024-06-20
TÜV Rheinland Japan Ltd.

100201-04-08 © TÜV, TUEV and TÜV are registered trademarks. Utilization and application requires prior approval.



(Translation)

Type Approval Certificate

Classification	Certification Ordinance Article 2-1-8 Spec. Low Power, Motion Sensor 57-64GHz
Type of emission, frequency and antenna power	K3N 60.5GHz 0.007W
Model Name	A121
License Holder	Acconeer AB
Manufacturer	Acconeer AB
Certificate number	005-103273
Certification date	2024-06-20

Approval as mentioned above is granted under the provisions of Article 38-24-1 of the Radio Law.

JRF-005-103273-001

2024-06-20

TÜV Rheinland Japan Ltd.

10000 h: 04.58 © TÜV, TUEV and TÜV are registered trademarks. Utilization and application requires prior approval.

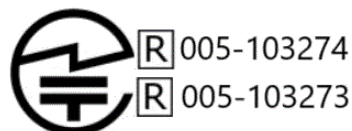



9 Mechanical Data

The A121 is available in fcCSP package for mounting on a substrate. The below table shows mechanical data:

Parameter	Min.	Typ.	Max.	Unit
Body X	5.15	5.20	5.25	mm
Body Y	5.45	5.50	5.55	mm
Body Z (height)		0.821	0.899	mm
Ball pitch	0.45	0.50	0.55	mm
Ball diameter	0.25	0.30	0.35	mm
Ball height	0.15	0.24		mm
Ball count		50		#

Table 15. Mechanical data.

The A121 footprint is shown in Figure 9.1.

Copper pad = $\emptyset.30\text{mm}$

Soldermask = $\emptyset.40\text{mm}$

Solder paste = $\emptyset.30\text{mm}$

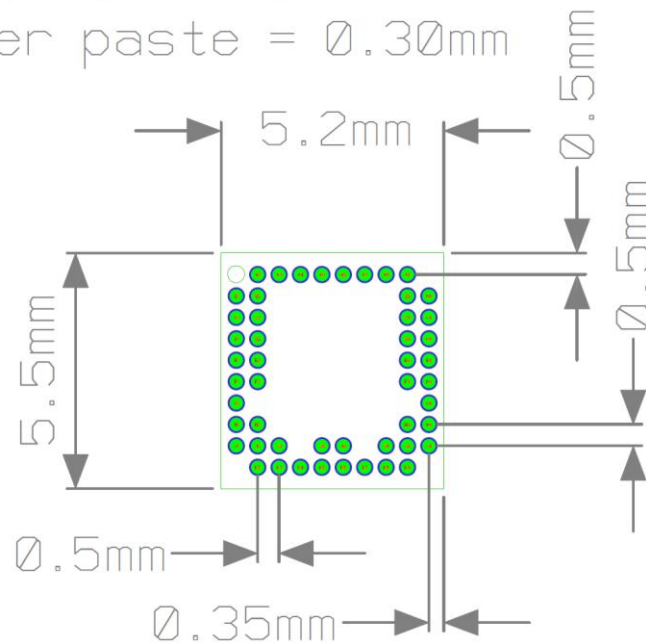

Figure 9.1. A121 footprint.



The physical layout of the A121 sensor is shown in Figures 9.2, 9.3 and 9.4.

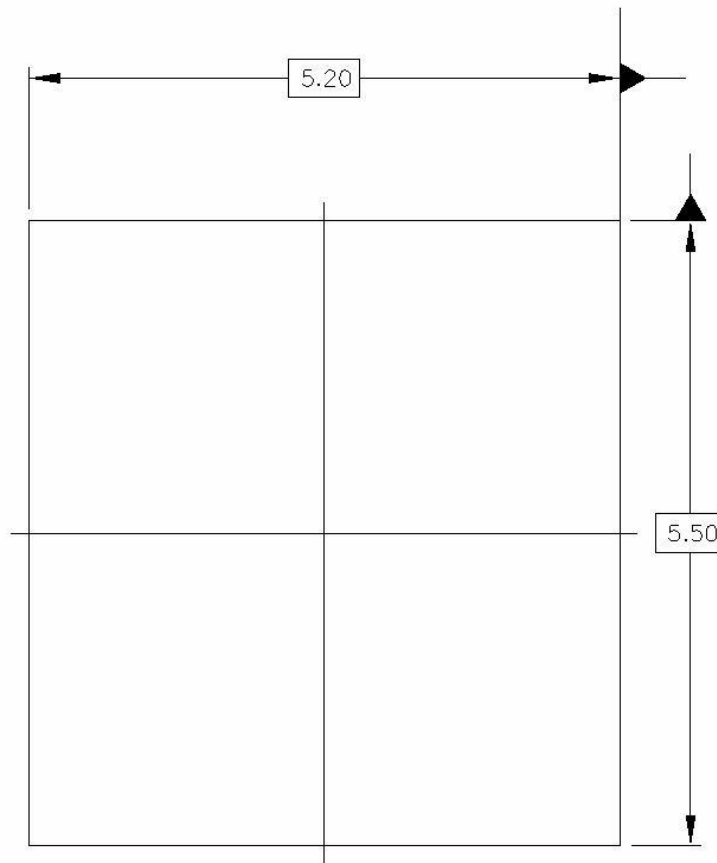

Figure 9.2. Physical layout of the A121 sensor, top view.

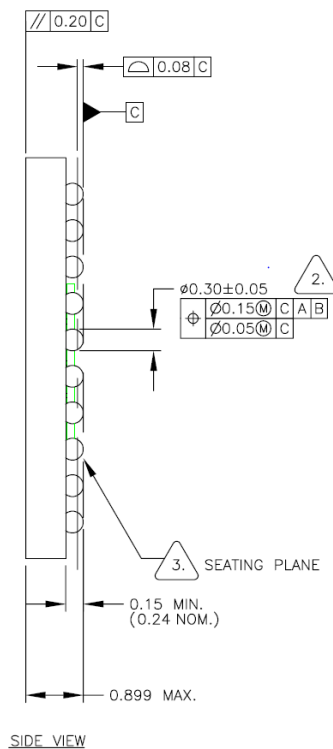

Figure 9.3. Physical layout of the A121 sensor, side view.

Primary datum C and seating plane are defined by the spherical crowns of the solder balls. Dimension is measured at the maximum solder ball diameter, parallel to primary datum C. All dimensions and tolerances conform to ASME Y14.5 – 2009.

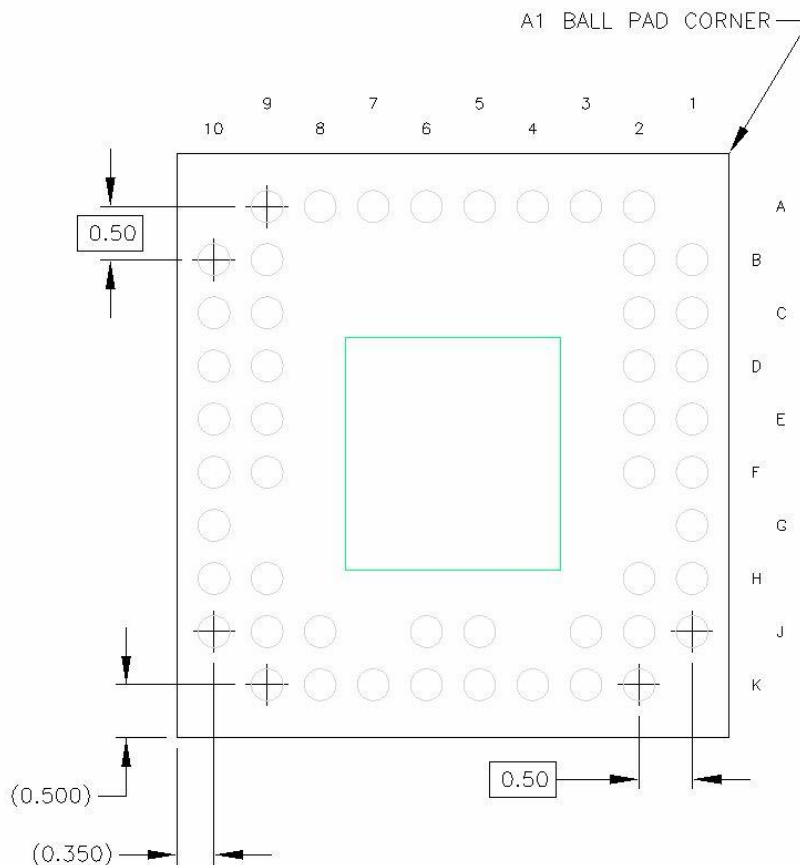

Figure 9.4. Physical layout of the A121 sensor, bottom view.

The bottom view shows 50 solder balls. The pitch of the BGA balls is 500 μm , the ball diameter is 300 $\mu\text{m} \pm 5 \mu\text{m}$ and the collapsed ball height is 0.244 \pm 0.050 mm.

9.1 Moisture Sensitivity Level and Recommended Reflow Profile

Acconeer A121 sensor is a Moisture Sensitive Devices (MSD) in accordance to the IPC/JEDEC specification. The Moisture Sensitivity Level (MSL) relates to the packaging and handling precautions required. A121 sensor is rated at MSL level 3.

Maximum number of reflow passes recommended for A121 is 2.

Soldering process qualified during qualification with “Preconditioning MSL 3: 30°C. 60%r.h., 192h, according to JEDEC JSTD20”, and qualified for soldering heat resistance according to JEDEC J-STD-020.

9.2 RoHS and REACH Statement

Acconeer A121 sensor meet the requirements of Directive 2011/65/EC of the European Parliament and of the Council on the Restriction of Hazardous Substances (RoHS) and the requirements of the REACH regulation (EC 1907/2006) on Registration, Evaluation, Authorization and Restriction of Chemicals.



10 Abbreviations

ADC	Analog digital converter
AiP	Antenna in package
API	Application programming interface
BGA	Ball grid array
BOM	Bill of materials
CE	"Conformité Européene" (which literally means "European Conformity")
CPHA	Clock phase
CPOL	Clock polarity
EIRP	Equivalent isotropically radiated power
ESD	Electrostatic discharge
ETSI	European Telecommunications Standards Institute
FCC	Federal Communications Commission
fcCSP	Flip-chip chip-scale package
FWHM	Full Width at Half Maximum
GND	Ground
HAL	Hardware abstraction layer
HPBW	Half power beamwidth
HWAAS	Hardware Accelerated Average Samples
LDO	Low-dropout regulator
MCU	Microcontroller unit
MIC	Ministry of Internal Affairs and Communication
MISO	Master input, slave output
MOSI	Master output, slave input
NC	No connect
PCR	Pulse coherent radar
PLL	Phase locked loop
PoR	Power on reset
RCS	Radar cross section
RF	Radio frequency
RLG	Radar Loop Gain
RX	Receiver
SNR	Signal-to-Noise Ratio
SPI	Serial peripheral interface
SS	Slave select
STD	Standard deviation
TCXO	Temperature compensated crystal oscillator
TX	Transmitter
XTAL	Crystal



Disclaimer

The information herein is believed to be correct as of the date issued. Acconeer AB (“**Acconeer**”) will not be responsible for damages of any nature resulting from the use or reliance upon the information contained herein. Acconeer makes no warranties, expressed or implied, of merchantability or fitness for a particular purpose or course of performance or usage of trade. Therefore, it is the user’s responsibility to thoroughly test the product in their particular application to determine its performance, efficacy and safety. Users should obtain the latest relevant information before placing orders.

Unless Acconeer has explicitly designated an individual Acconeer product as meeting the requirement of a particular industry standard, Acconeer is not responsible for any failure to meet such industry standard requirements.

Unless explicitly stated herein this document Acconeer has not performed any regulatory conformity test. It is the user’s responsibility to assure that necessary regulatory conditions are met and approvals have been obtained when using the product. Regardless of whether the product has passed any conformity test, this document does not constitute any regulatory approval of the user’s product or application using Acconeer’s product.

Nothing contained herein is to be considered as permission or a recommendation to infringe any patent or any other intellectual property right. No license, express or implied, to any intellectual property right is granted by Acconeer herein.

Acconeer reserves the right to at any time correct, change, amend, enhance, modify, and improve this document and/or Acconeer products without notice.

This document supersedes and replaces all information supplied prior to the publication hereof.

© 2025 by Acconeer – All rights reserved

